



DVB-SH

**The new standard for Satellite services to
Handheld devices (SH) below 3 GHz**

Riccardo De Gaudenzi

ESTEC ESA Technical and Quality Management Directorate



Part I: General Introduction

DVB-SH Applications

- Broadcasting of classic Radio and TV content;
- Broadcasting of audio or video content customized for Mobile TV (e.g. virtual TV channels, pod-casts);
- Data delivery (“push”), e.g. for ring tones, logos;
- Video on demand services;
- Informative services (e.g. news) including location-based services;
- Interactive services, via an external communications channel (e.g. UMTS or satellite return link)

DVB-SH General Features

- DVB-SH supports mobile broadcasting for frequencies up to 3 GHz for hybrid satellite/terrestrial networks
- Seamless service continuity between SC and CGC coverages;
- Support of all reception conditions associated to portable and mobile terminals: indoor/outdoor, urban/sub-urban/rural, static/mobile conditions. Typical mobility conditions covers pedestrian as well as land vehicular scenarios;
- Possible implementation of power saving schemes to minimize the power consumption of battery activated terminals in order to maximise autonomy;
- Local insertion of broadcast services on CGC;
- Use different kinds of distribution network to feed the CGC repeaters, such as Satellite (DVB-S/S2) and/or terrestrial (Optical fiber, Wireless Local Loop, xDSL...) resources;

DVB-SH General Features

- Two main system configurations:
 - SH-A uses OFDM both on the satellite and the terrestrial link
 - SH-B uses TDM on the satellite link and OFDM for the terrestrial link
 - In both cases satellite/terrestrial SFN and MFN configurations can be supported
- Two receiver classes:
 - The first (Class 1 Receiver) is able to cope with rather short interruptions and mobile channel fading using appropriate mechanisms on the physical layer but supports the handling of long interruptions using redundancy on the link layer
 - The second (Class 2 Receiver) is able to handle long interruptions (in the order of magnitude of 10 seconds) directly on the physical layer. This is made possible via the use of a large memory directly accessible to the receiver chip.

System Architecture

- Universal coverage by combining a Satellite Component (SC) and a Complementary Ground Component (CGC):
 - in a cooperative mode, the SC ensures geographical global coverage
 - CGC provides cellular-type coverage.
- Target terminals include handheld (PDAs, mobile phones), vehicle-mounted, nomadic (laptops, palmtops...) and stationary terminals
- The repeaters may be of three kinds:
 - “Terrestrial Transmitters”
 - “Personal Gap-fillers”
 - “Mobile transmitters”

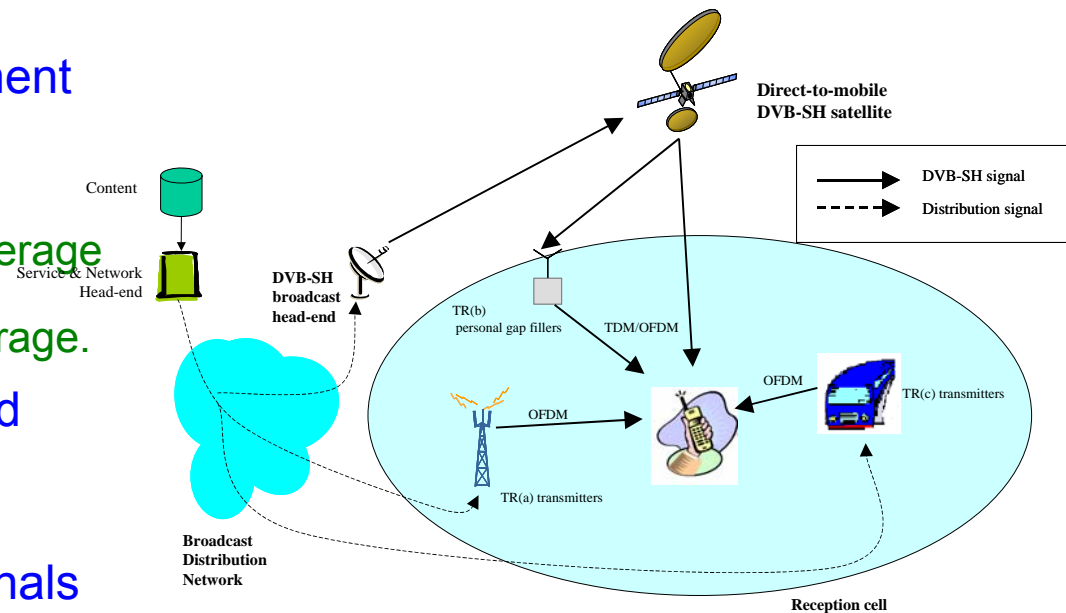

DVB-SH versus DVB-H

- TDM option for satellite on top of OFDM
- More powerful physical layer FEC
- Code combining capability for MFN mode
- Programmable large time span PL interleaver (Class 2)
- 1k OFDM mode added
- Enhanced link layer FEC (multi-burst iFEC)

SH-A System Architecture

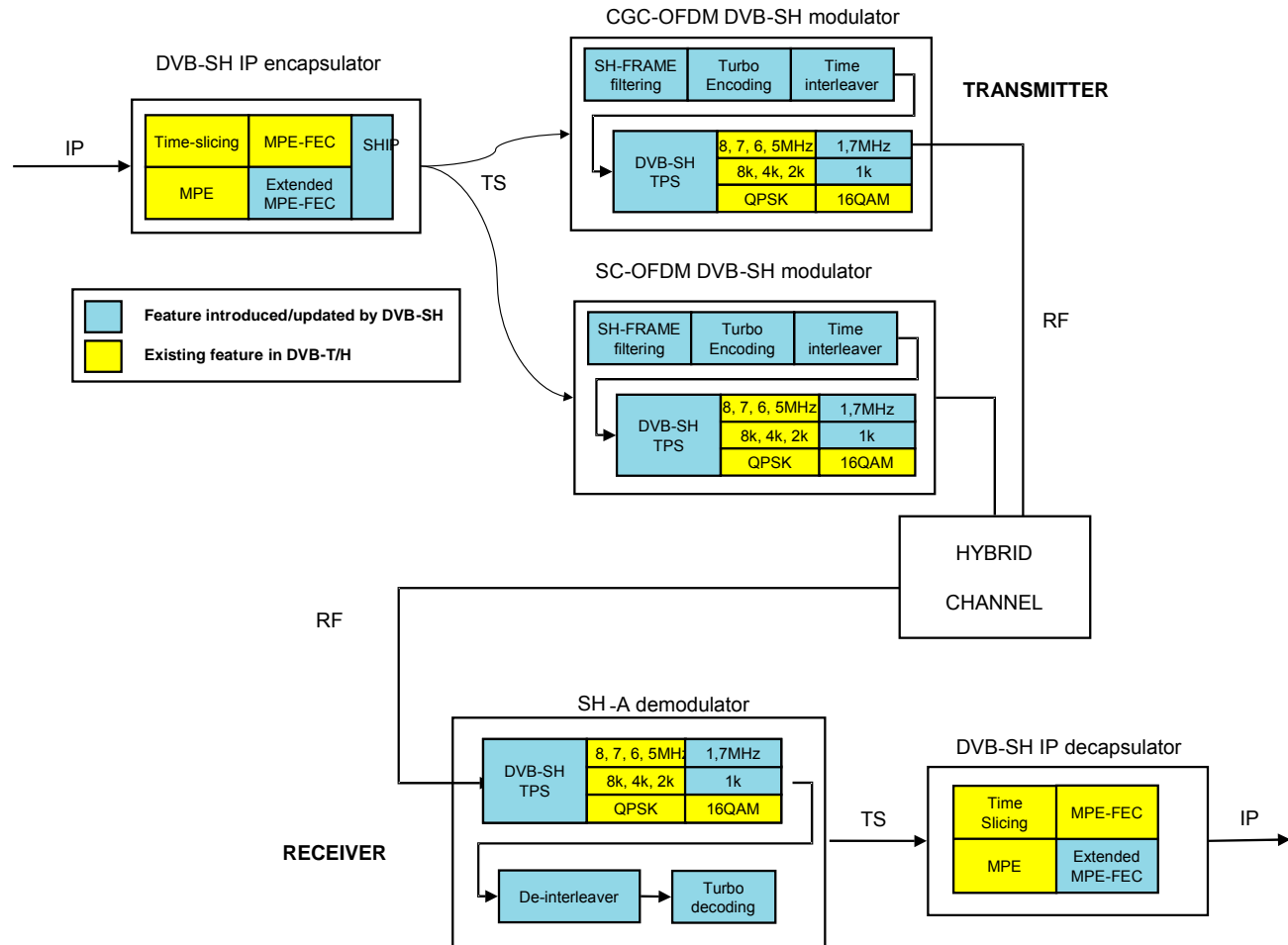



SH-B System Architecture

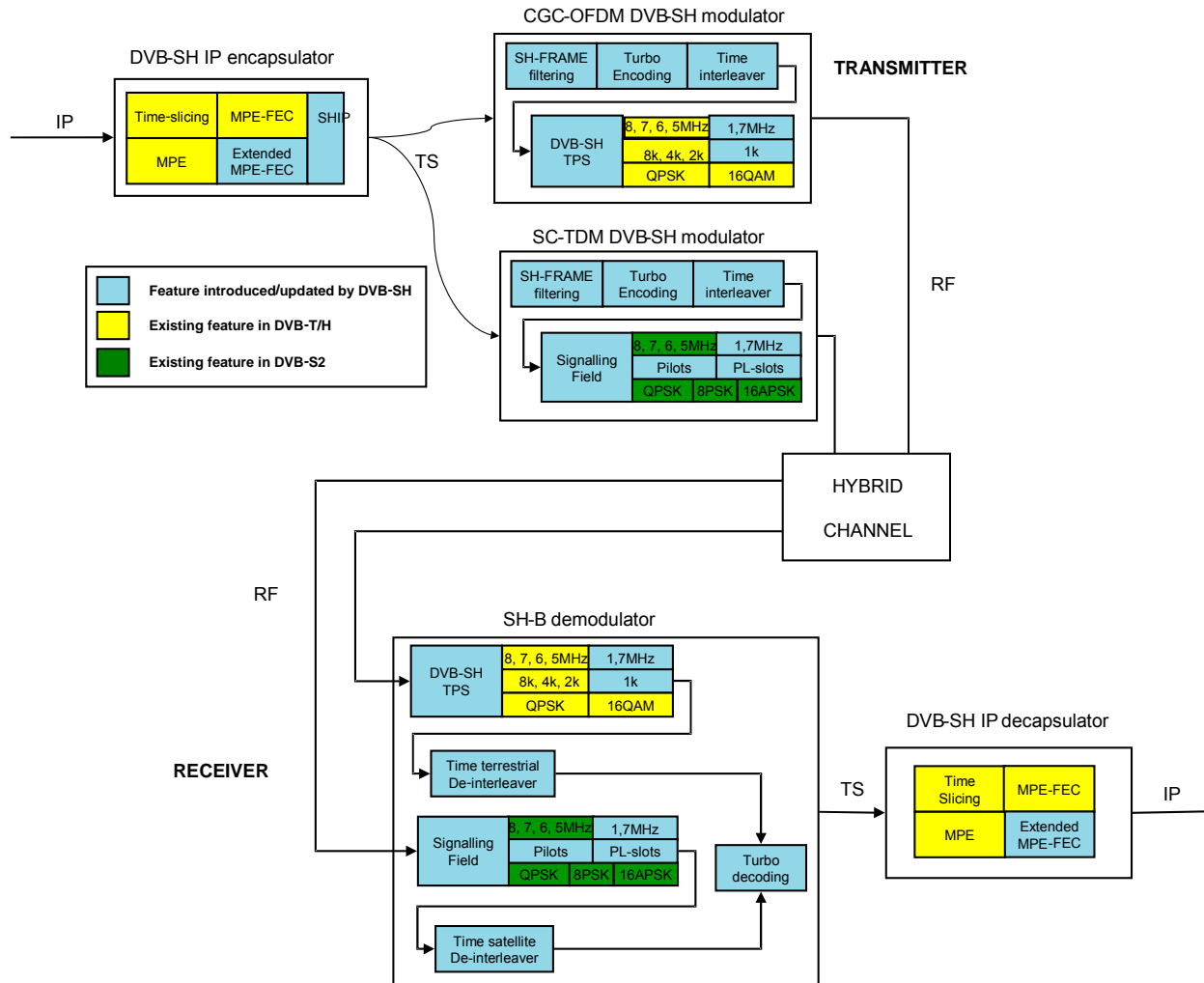

Frequency Planning & Throughput Aspects

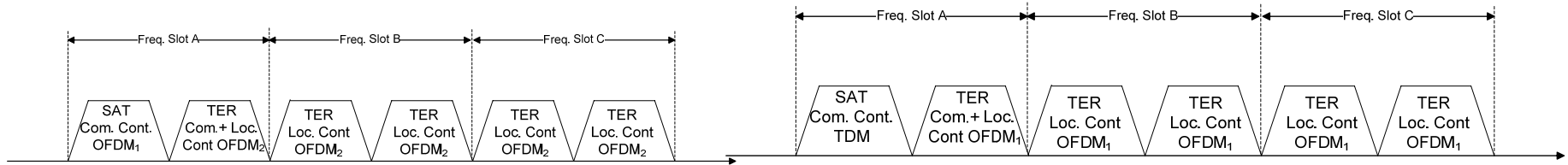

Config 1 (SH-A, MFN, Split band)

Config 4 (SH-B, MFN, split band)

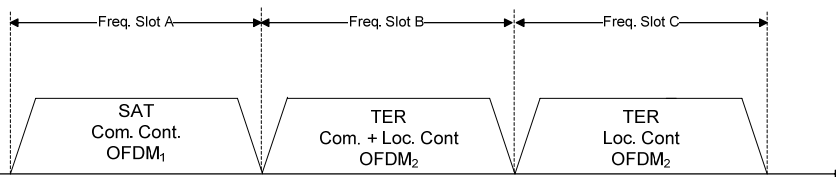

Config 2 (SH-A, MFN, No split band)

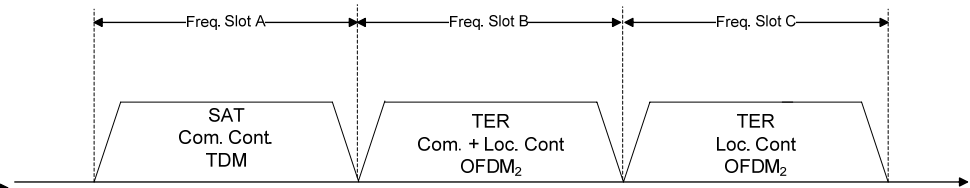

Config 5 (SH-B, MFN, No split band)

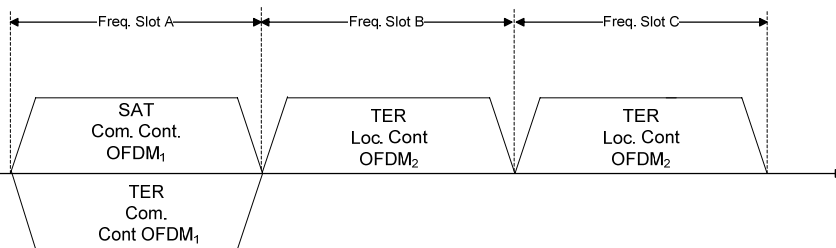

Config 3 (SH-A, SFN, No Split band)

Numerical Example Spectral Efficiencies

Configuration	$\eta(\text{TDM})$	$\eta(\text{OFDM})$	$\eta(\text{OFDM})$ Hybrid or Sat	$\eta(\text{COM})$	$\eta(\text{TOTAL})$ with $f_R=3$	System (6 beams)
1) SH-A, MFN, Split	NA	0,75	0,49	0,25	$(3 - \frac{1}{2}) \times 0,49 = 1,23$	$6/3 \times 1,23 = 2,46$
2) SH-A, MFN, No split	NA	0,75	0,49	0,49	$2 \times 0,75 = 1,5$	$6/3 \times 1,5 = 3$
3) SH-A, SFN, No Split	NA	0,75	0,49	0,49	$2 \times 0,75 + 0,49 = 1,99$	$6/3 \times 1,99 = 3,98$
4) SH-B, MFN, Split	0,53	0,75	NA	0,27	$(3 - \frac{1}{2}) \times 0,53 = 1,33$	$6/3 \times 1,33 = 2,66$
5) SH-B, MFN, No Split	0,53	0,75	NA	0,53	$2 \times 0,75 = 1,5$	$6/3 \times 1,5 = 3$

Spectral Efficiency Conclusions

- When the content to be broadcasted is different for different regions (e.g. linguistic regions) multi-beam satellite configuration increase the common content spectral efficiency proportionally to the ratio between the number of beams and the frequency reuse factor
- SH-A/SFN configuration provides the highest overall spectral efficiency thanks to SFN operation between satellite and terrestrial gap fillers
- SH-B/No-split achieves a slightly higher spectral efficiency than SH-A for common content delivery but has a lower spectral efficiency for local content distribution than SH-A [Power efficiency issues (e.g. HPA nonlinearity effects) are not part of this comparison]
- Any split configuration provides half of the spectral efficiency for common content distribution compared to the corresponding non split ones:
 - This strong efficiency reduction is balanced by potential advantages in terms of exclusion zones for common content delivery
 - Furthermore the split configuration makes it possible to increase the satellite C/N in power limited cases

Network Synchronisation Aspects

- A pre-compensation of the time delay variation must be done at the Gateway location.
- It is ensured by comparing the locally received signal with a local reference delayed by twice the gateway to satellite reference position path duration
- For near GEO satellites a differential delay of up to about ± 400 ms remains between the direct and indirect paths.
- These differential delay variations must be compensated for at the level of each repeater using satellite ephemeris position

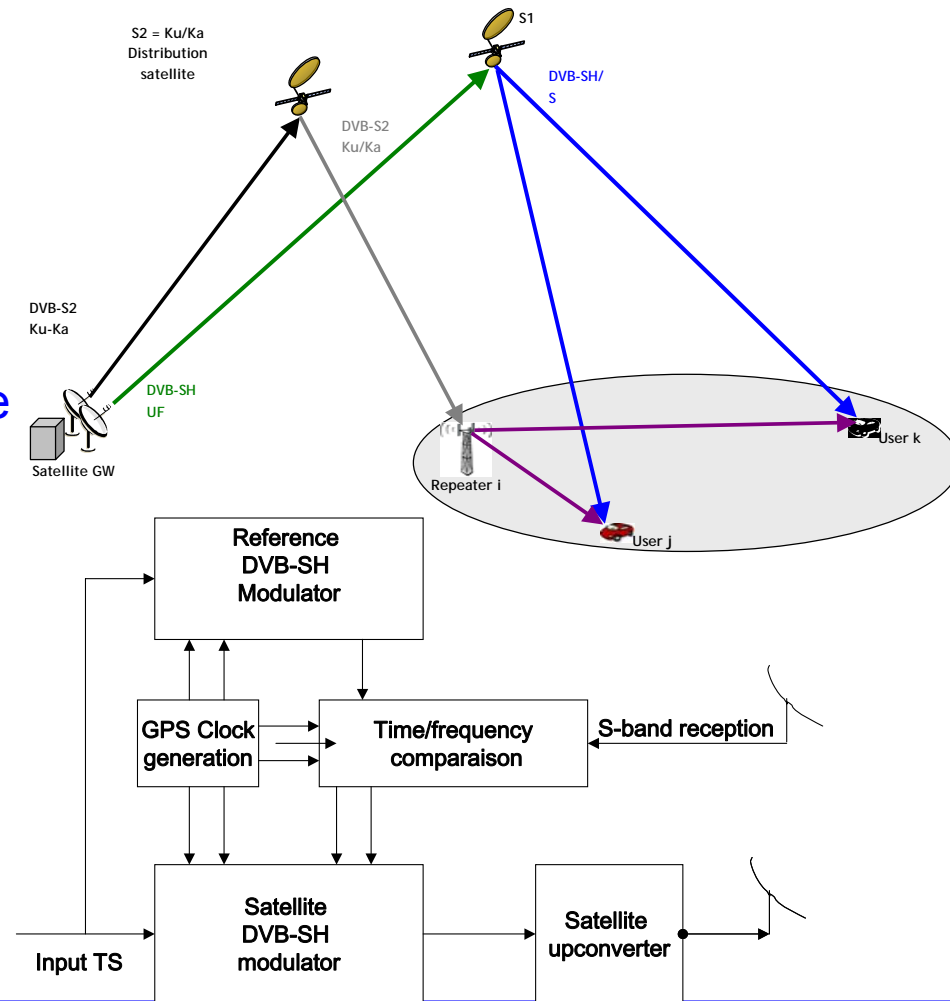



Part II: The DVB-SH waveform

DVB-SH Functional Block Diagram

Both modes:

- Mode adaptation: CRC-16 and insertion of the Encapsulation Frame Header.
- Stream adaptation: padding and scrambling of the Encapsulation Frame.
- Forward Error Correction (FEC) encoding using 3GPP2 [3] turbo code.
- Bit-wise interleaving applying on a FEC block. The latter is meanwhile shortened to comply with the modulation frame structure of OFDM and TDM.
- Convolutional time interleaving and framing

SH-A OFDM mode:

- Symbol interleaver.
- Bit mapping to the constellation.
- OFDM framing with pilots and TPS insertion

SH-B TDM mode:

- Bit mapping to the constellation.
- TDM physical layer framing.
- Pilots insertion and scrambling.
- Pulse shaping and quadrature modulation

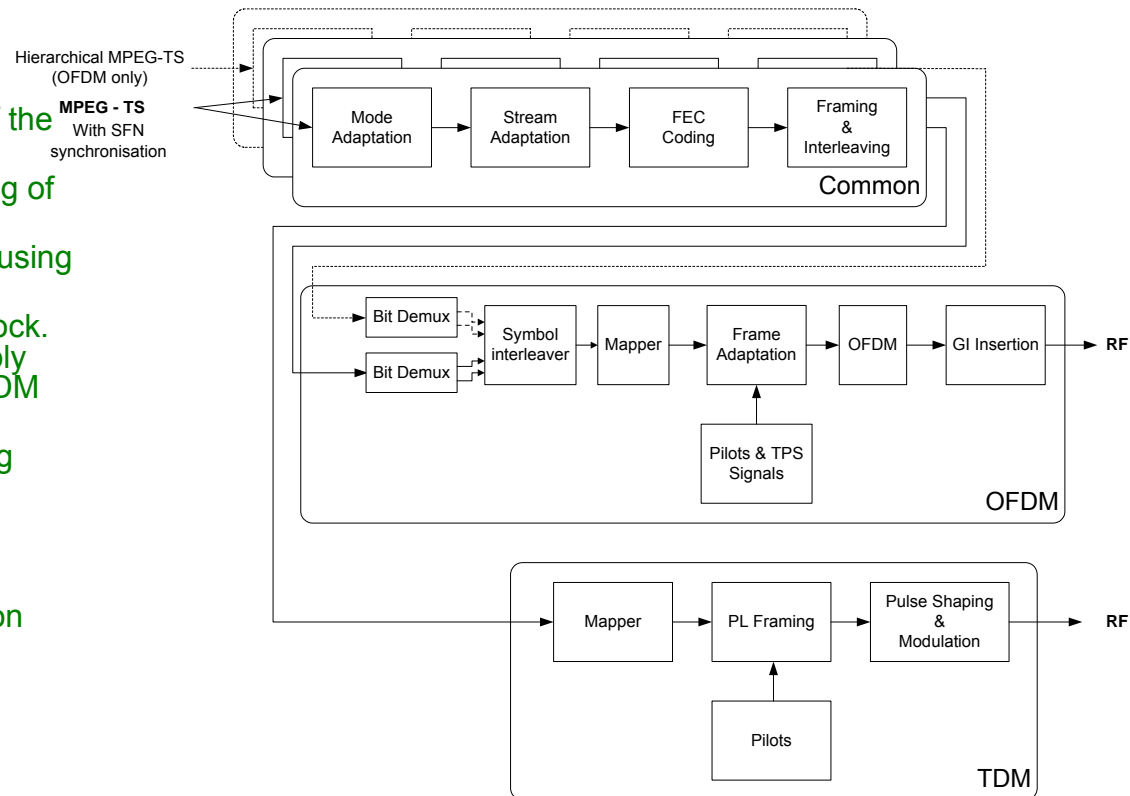

Mode Adaptation

1. Sync byte removed from TS
2. CRC-16 added for providing error detection capability for upper layers
 - One CRC computed every user MPEG Packet (UP) length of 188 bytes
3. A fixed length Encapsulation Frame Header (EHEADER) of 114 bits shall be inserted in front of the DATAFIELD
 - One CRC computed every EHEADER
4. DFL=12096 bits for MPEG TS corresponding to 8 MPEG packets

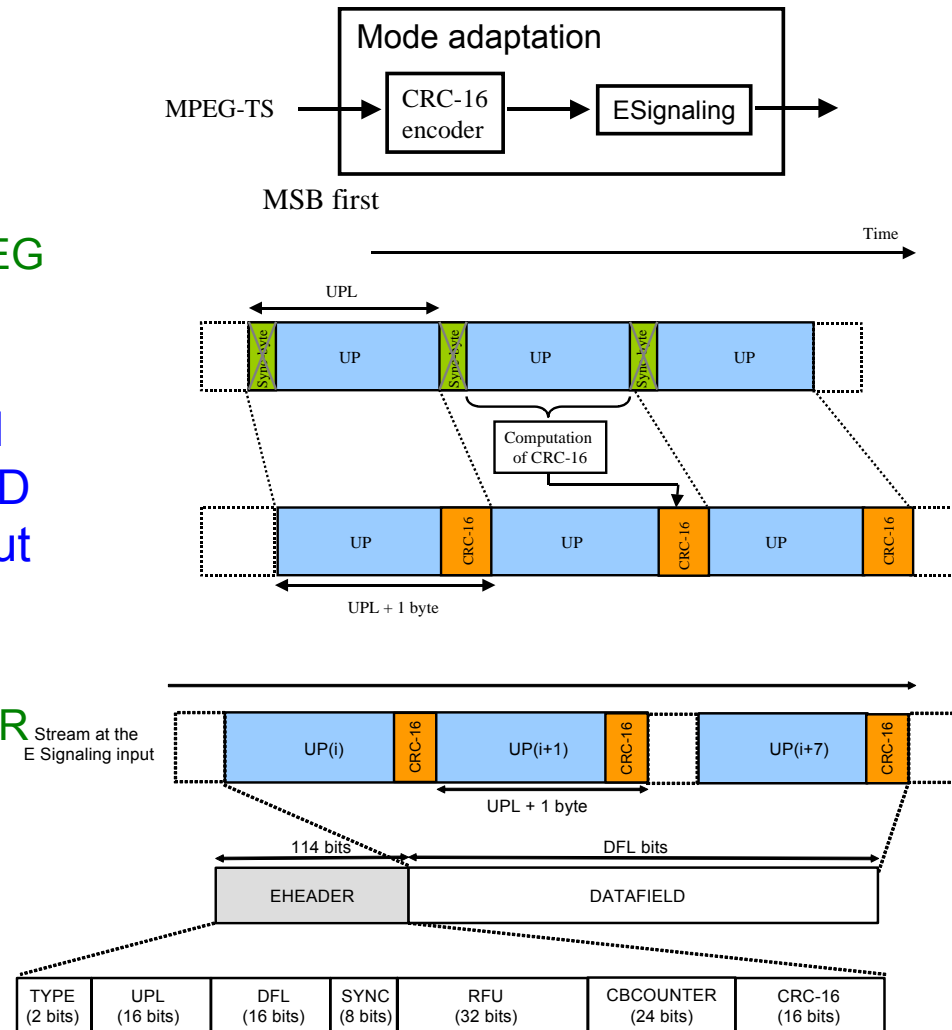

Stream Adaptation

- Stream adaptation provides padding to complete a constant length (TC FEC input = 12 282 bits) Encapsulation Frame matching the PL FEC (EFRAME) and performs scrambling
 - Padding is achieved appending zero bits to the DATAFIELD (72 bits for MPEG TS)
 - Scrambling is obtained using a PRBS generator X-oring the padded frame

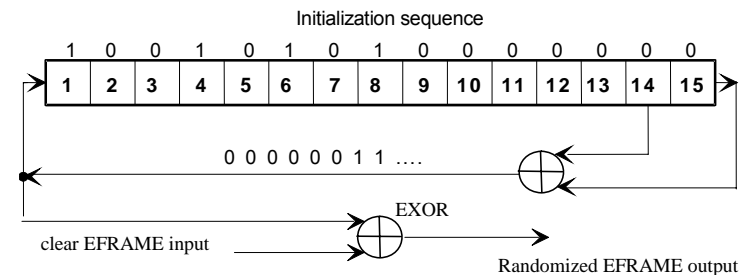
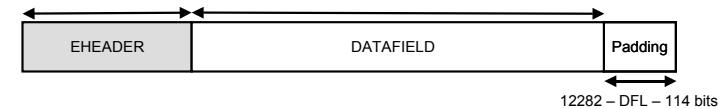
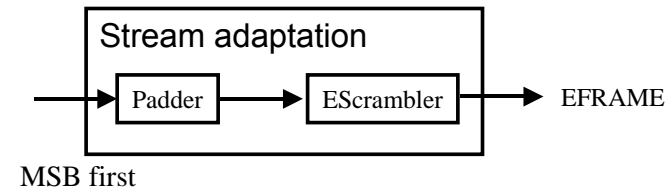

FEC Encoding

- 3GPP2 turbo encoder reused with some modifications
- Supported coding rates:
 - 1/5, 2/9, 1/4, 2/7, 1/3, 2/5, 1/2, 2/3
 - Some code rates supports code combining feature (1/3, 1/2, 2/3)
- Two FEC block sizes (1146 for signalling and 12282 for normal frames input bits)

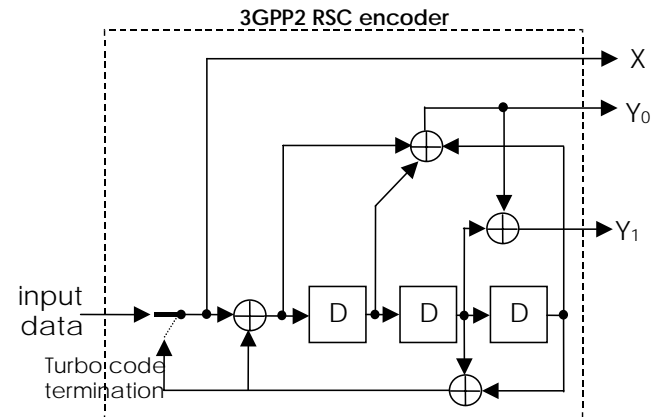
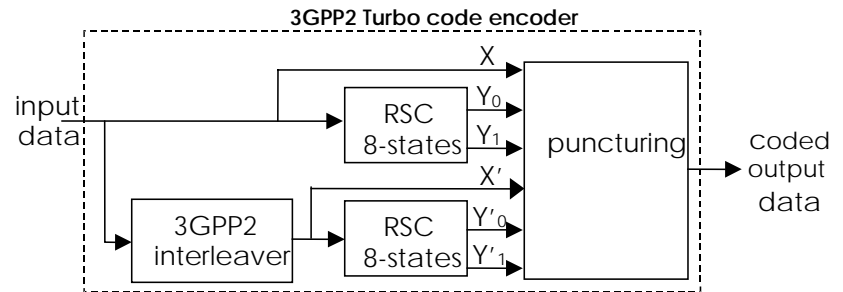

Channel interleavers

- Interleavers are necessary to enhance the resistance of the waveform to:
 - short-term fading
 - medium-term shadowing/blockage impairments
- Short term fading is combated through a FEC bit wise (block) interleaver
- Longer term fading/shadowing is combated through a convolutional time interleaver
- The time interleaver maximum size is driven by the need to support LMS channel with Class 2 receivers
- Puncturing also take place here to adapt the code rate to PL frames

Time Interleaver

- A flexible convolutional 48 branches convolutional time interleaver is adopted to span large time span
 - Half memory occupation
 - Half decoding delay
- The interleaver exploits 126 bit cells
- Reconfigurable size of the 48 branches delays through:
 - TPS tables for OFDM
 - Header signalling field for TDM
- Class 1 time interleaver size limited to 6528 x 126 bits (about 200 ms)
- Class 2 time interleaver size limited to 417792 x 126 bits (about 30 sec)

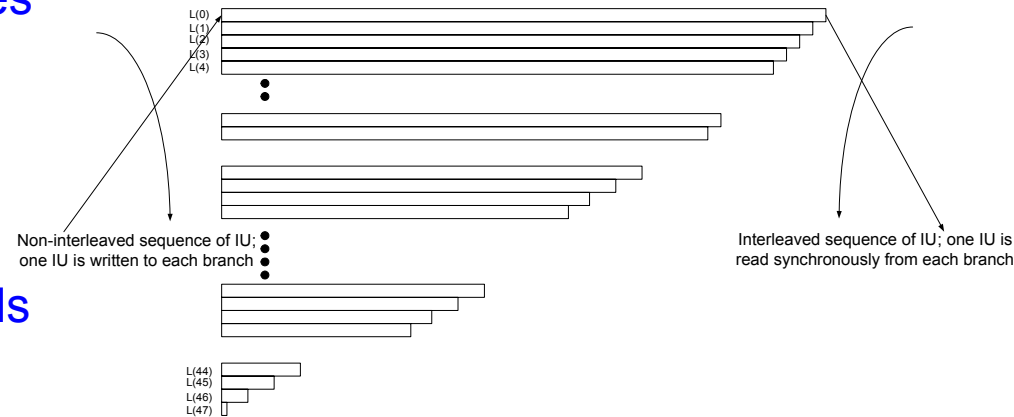

Examples of Time Interleaver Profiles

QPSK R=1/2 Short

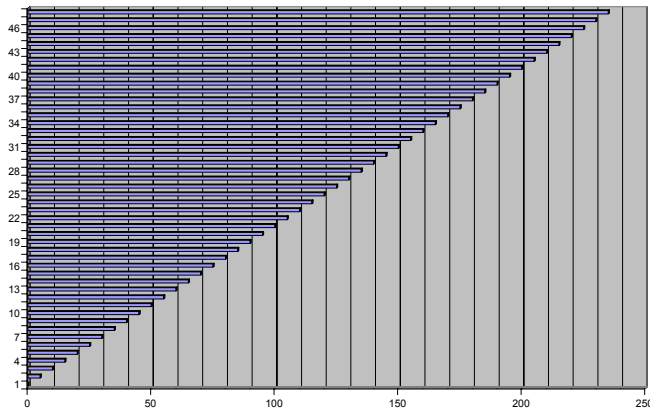

Class 1 uniform short profile

QPSK R=1/3 Uniform-late

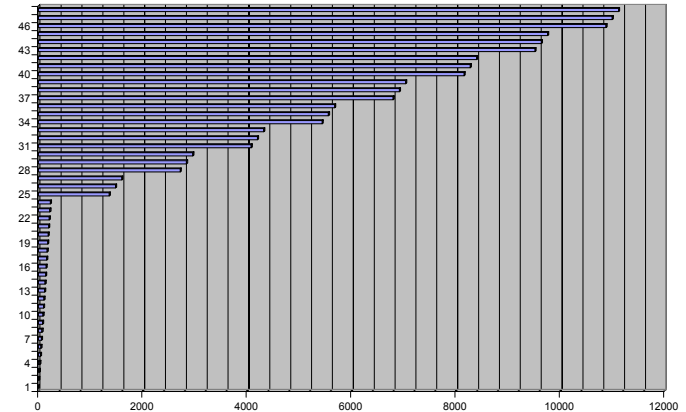

Class 2 uniform-late long profile

QPSK R=1/3 Uniform

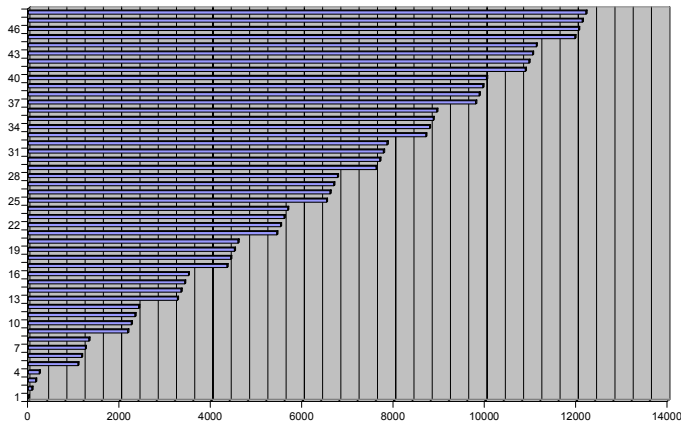

Class 2 uniform long profile

QPSK R=1/3 Early-Late

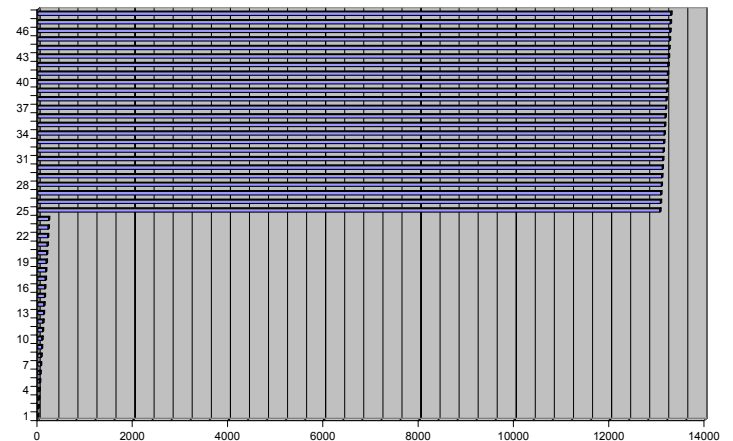

Class 2 early-late profile (time diversity)

Mixing of Different Satellite/Terrestrial Profiles

- In MFN networks it is possible to combine different interleaver profiles for the SC and CGC
- Delay equalization is obtained through an additional transmitter delay

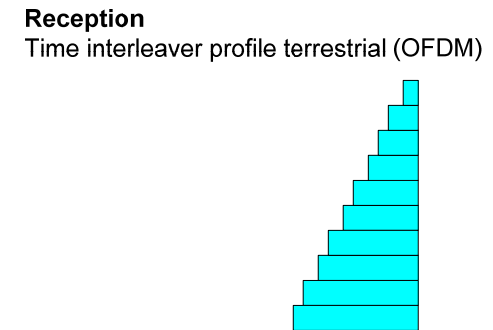
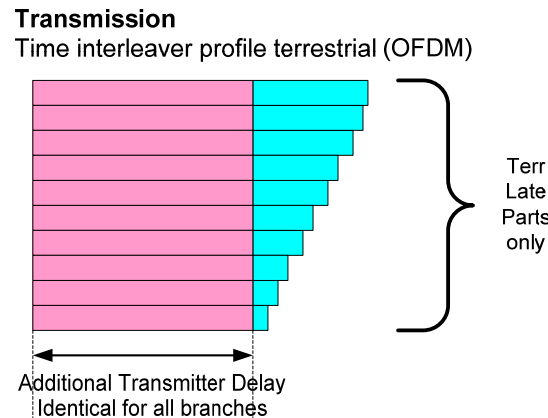
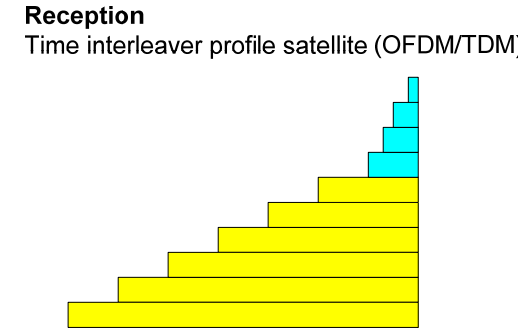
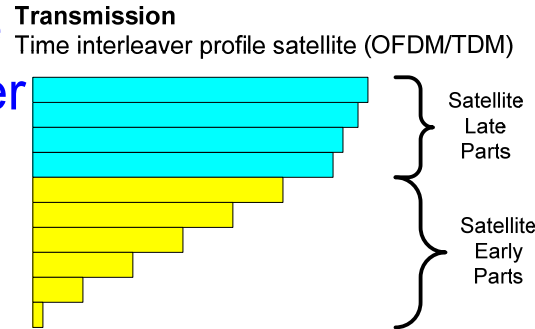

SH-A Interleaving and Rate Adaptation

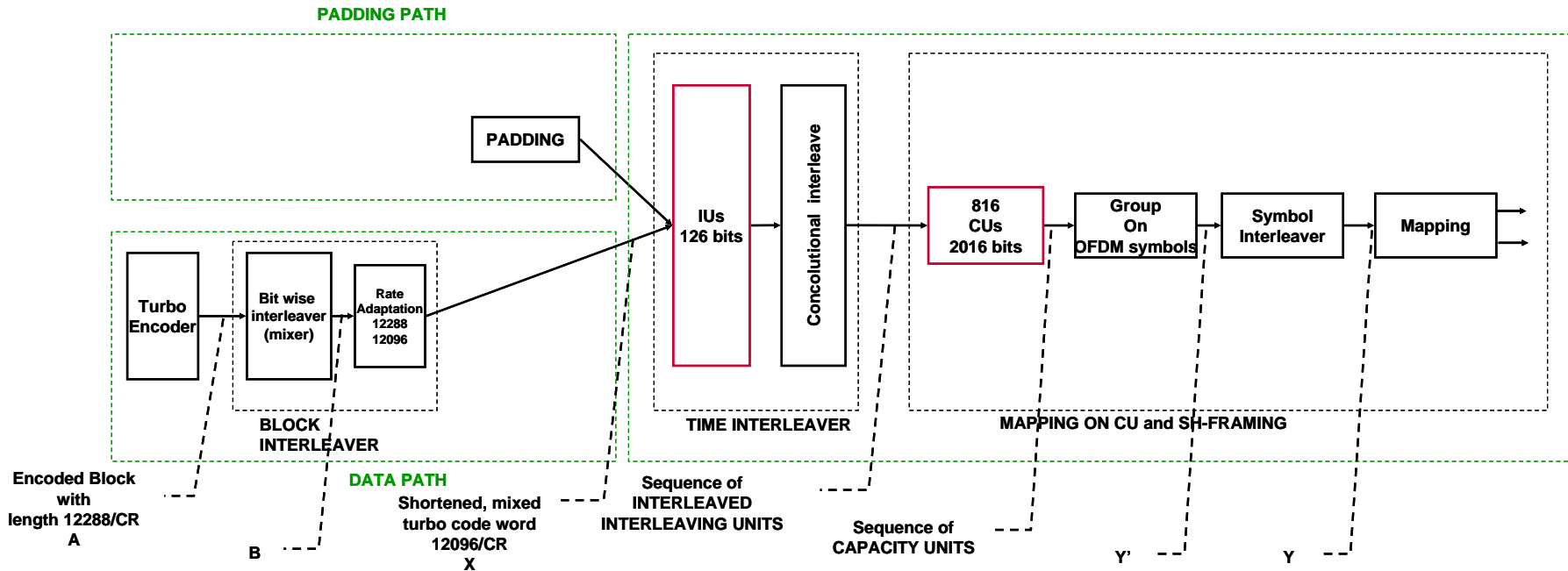

SH-B Interleaving and Rate Adaptation

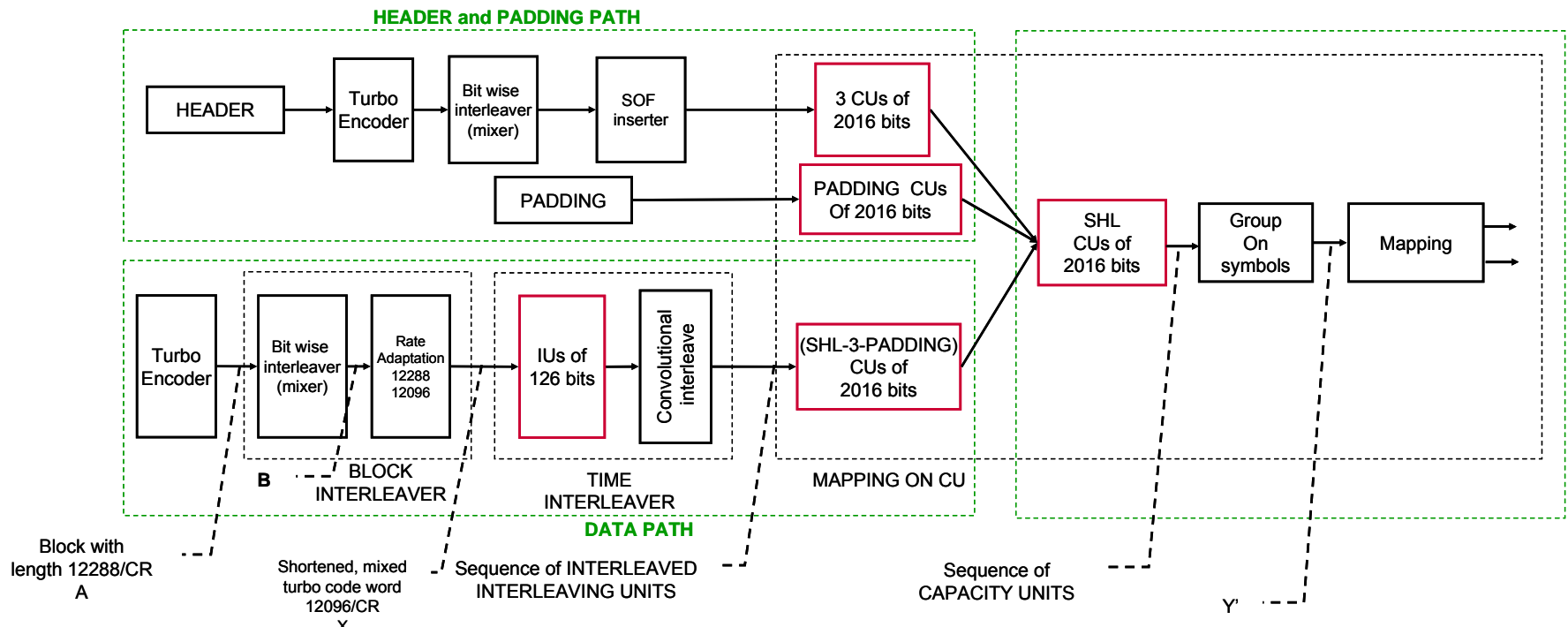

SH Frame Structure

- Two different structures for OFDM and TDM
- OFDM:
 - Data + padding
- TDM:
 - Data + padding + header
- DATA part:
 - integer number of punctured code words generated after the bitwise interleaver (integer # CUs)
- PADDING PART:
 - The PADDING part (if existing) is used to complete the SH frame, such that it always contains a fixed number of CU, independent of the chosen code rate
- HEADER:
 - 3 CUs long signalling field (TDM only)

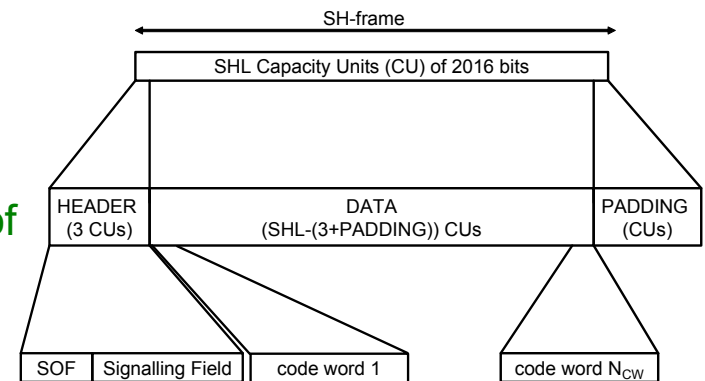
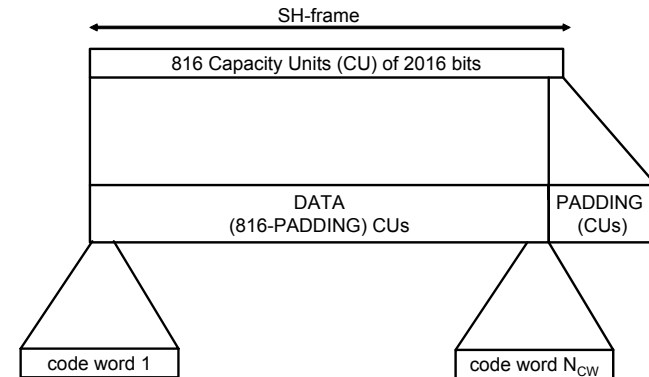

Interface to TDM Modulator

- To simplify the diversity reception of both signals in hybrid TDM/OFDM environment, the framing duration for the TDM waveform is made identical to the framing duration for the OFDM waveform
- SH frame CUs is dependent on the modulation and coding option selected
- Bit mapping to constellations (QPSK, 8PSK and 16APSK) is Gray and follows DVB-S2 standard
- As OFDM definition relies on the DVB-T standard, TDM Frame time duration is constrained by the OFDM frame duration which value varies with bandwidth, guard Interval setting and modulation order



TDM Framing, Pilot insertion, Scrambling, Pulse shaping

- TDM framing organised in PL Slots PL SLOTS (2176 symbols)
- 2 groups of QPSK pilots (80 symbols) inserted every 1088 symbols
- Complex baseband scrambling of the baseband I-Q samples for energy dispersal (same as DVB-S2/3GPP PL scrambling)
- SRRC pulse shaping follows (roll-off factors 0.15, 0.25, 0.35)

Modulation	CU per PL SLOT
QPSK	2
8PSK	3
16APSK	4

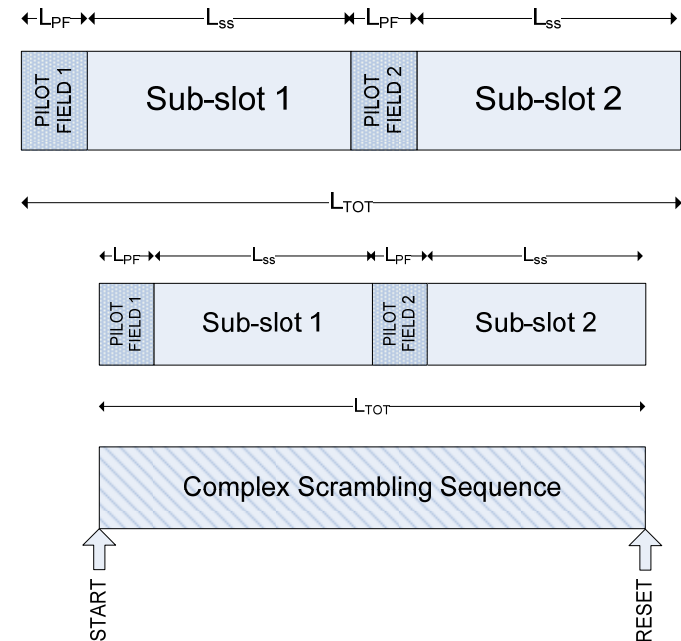

Interface to OFDM Modulator

- The capacity units are aligned to the OFDM symbols
- To simplify demodulation an integer number of CU maps to another integer number of OFDM symbols, dependent on FFT sizes and selected subcarrier modulation
- Up to 2 bit streams coming out of the channel interleaver (2 in case of hierarchical modulation)
- The interleaved bit streams are demultiplexed into $\log_2 M$ sub-streams to match the # bits/modulation symbol
- Symbol interleaver to map the bit sub-streams onto the OFDM codeword (obtained through permutations)
- Bit mapping onto QAM as for DVB-H

OFDM Framing, Pilot insertion

- OFDM framing as DVB-H but with one new 1k FFT mode
- Use of continual and scattered pilots as well as TPS carriers (same as DVB-H)
- DVB-H TPS extended to cover the time interleaver parameters signalling

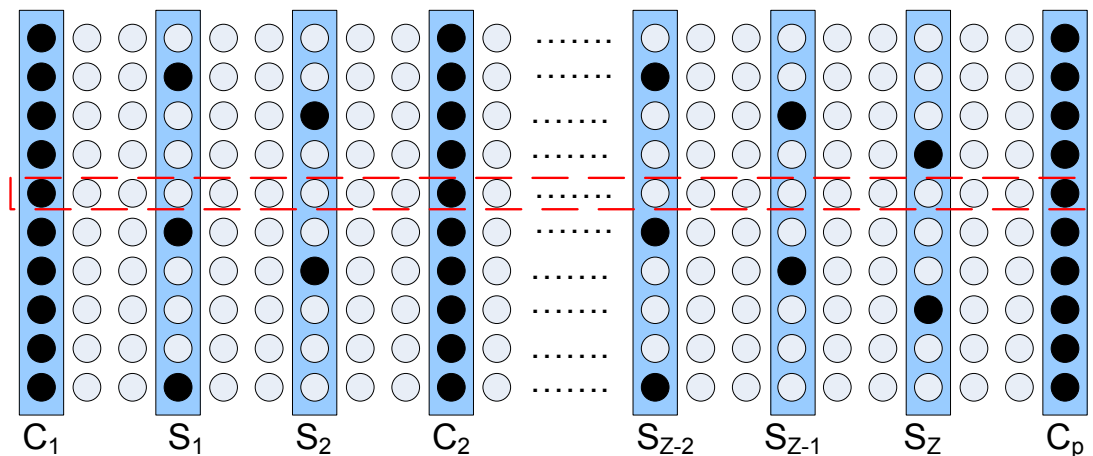

The MPE-IFEC

- The MPE-IFEC has been designed taking account:
 - the necessity to have a protection scheme to counteract the disturbances in DVB-SH transmission and reception environments
 - to address legacy requirements to existing DVB-H equipment
 - to enable a flexible solution which permits service specific adjustments
 - to provide the option to do further adjustments and optimizations during deployments
- To achieve this, the MPE-IFEC, contrarily to MPE-FEC, encodes over several time-slice bursts, which enables to increase the LL interleaver duration
- Reed Solomon FEC used (DVB-H legacy)

MPE-IFEC Features

- **Compatibility with DVB-H link layer (MPE sections):** MPE-IFEC is introduced in a way that it does not modify MPE section format, but only introduces one new sections type, the MPE-IFEC section.
- **Support of MPE-FEC:** permits the concurrent use of MPE-FEC and MPE-IFEC sections in one burst. However the support of simultaneous MPE-FEC and MPE-IFEC decoding in DVB-SH is for further study and therefore the parallel sending of MPE-FEC and MPE-IFEC on the same elementary stream is not allowed.
- **Support long interleaving:** MPE-IFEC allows significantly enhanced performance (as measured by ESR5) in LMS channels when compared to MPE-FEC as demonstrated by simulations. This performance benefits can be achieved as the MPE-IFEC encoding process spans several time-slice bursts. MPE-IFEC requires a burst numbering which is signaled in MPE-IFEC headers.
- **Support of different service requirements:** The MPE-IFEC can be configured to enable a variety of configurations providing flexibility for the network operator. Guidelines are provided later in this section on how to select these parameters.
- **Support fast zapping:** Inter burst FEC protection is adversely affecting latency, and therefore also has influence on channel zapping times. By sending MPE sections in each burst, immediate access and processing of these MPE sections is possible in case no errors have occurred. As reception continues, additional parity is received and MPE-IFEC protection can progressively protect the data by doing an early decoding. After some time, late decoding is possible.
- **Support a variety of FEC codes:** the framework can support a variety of codes, currently Reed Solomon is the only code supported by SSP, other FEC codes are for further study.



Part III: Main Performance Results from the Implementation Guidelines

Theoretical AWGN Performance

Code rate	QPSK	16QAM
1/5	-3,6	0,7
2/9	-3,1	1,3
1/4	-2,5	1,9
2/7	-1,8	2,8
1/3	-0,9	3,7
2/5	0,1	5,0
1/2	1,4	6,8
2/3	3,5	9,7

Theoretical C/N (dB) in AWGN channel for OFDM @ BER = 10^{-5}

Code rate	QPSK	8PSK	16APSK
1/5	-3,9	-1,3	0,4
2/9	-3,4	-0,7	1,0
1/4	-2,8	-0,1	1,6
2/7	-2,1	0,7	2,5
1/3	-1,2	1,6	3,4
2/5	-0,2	2,7	4,7
1/2	1,1	4,4	6,5
2/3	3,2	6,9	9,4

Theoretical C/N (dB) in AWGN channel for TDM @ BER = 10^{-5}

Within 1 dB from Shannon bound!

PL versus LL Protection

- DVB-SH supports both ways PL and LL to counteract LMS channel impairments
- Let assume that the overall FEC redundancy overhead is fixed to:

$$\delta = \frac{1}{r} - 1$$
 being r the overall FEC coding rate
 - PL protection is based on PL FEC with large time span convolutional interleaver; $r=r_{PL}$ thus the demodulator threshold is the minimum possible for given overall spectral efficiency
 - LL protection is based on PL FEC with a FEC with limited time span convolutional interleaver followed by LL MPE-IFEC (RS FEC with interleaver spanning several bursts); $r=r'_{PL}r'_{LL}$ thus the demodulator threshold is higher than PL only protection because $r'_{PL}>r_{PL}$
- In general for a given overall FEC redundancy and interleaver time span PL should have superior performance than LL protection
- The PL protection gain vanishes for on/off type of channels. In this case what matters is the FEC erasure correction capability which is mainly related to the FEC code rate (max erasure rate $\approx 1-r$)

PL versus LL Protection

- Interleaving can be seen as time-averaging of the received C/N
- PL only protection allows to reduce the demodulator threshold (average C/N) required
- This helps in channels that are not on/off such as rural tree shadowing
- For this type of channels link margins help to get packets decoded
- PL interleaver works on soft bits => memory requirement higher than LL

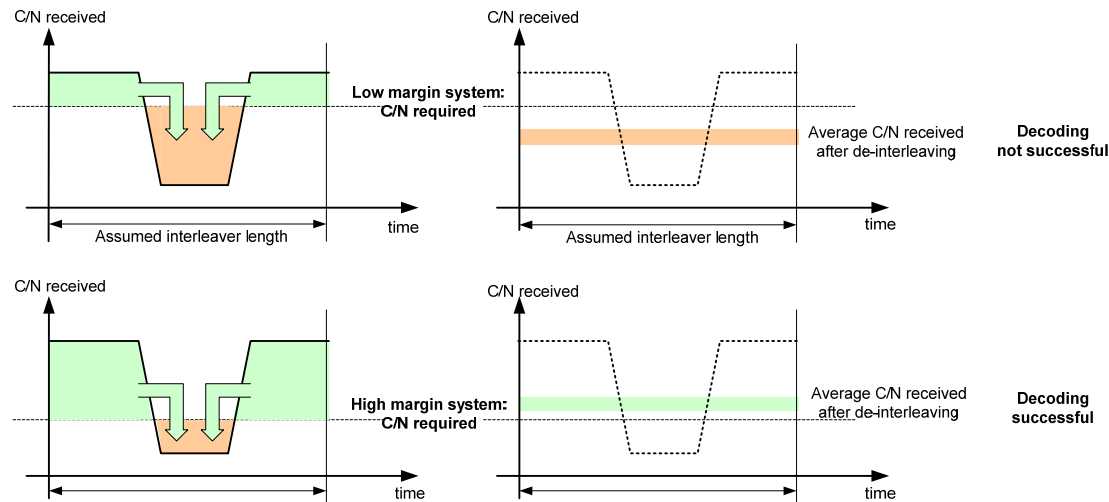

Quality of Service Measurement Approach

- BER/FER only used over AWGN and TU6 channels
- For more complex mobile channels need to use a performance criterion close to user acceptable video quality perception
- Need to look at second order MPEG packets error distribution => ESR5(20) agreed to be good enough but it requires long statistics
- **ESR5(20) criterion is fulfilled when in a time interval of 20 seconds there is at most one second in error**
- For terrestrial TU6 channel ITU indicated that 99% fulfilment ratio is satisfactory - No similar rule existing for satellite LMS channel
- Terrestrial TU6 channel ESR5 MPEG FER correspondence not valid for LMS

The TU6 Terrestrial Channel Model

- Classical channel urban model adopted for terrestrial wireless communication systems
- 6 independent rays tapped delay line model with different delays for each tap
- Does not include shadowing phenomena

Tap number	Delay (us)	Power (dB)	Doppler spectrum
1	0,0	-3	Rayleigh
2	0,2	0	Rayleigh
3	0,5	-2	Rayleigh
4	1,6	-6	Rayleigh
5	2,3	-8	Rayleigh
6	5,0	-10	Rayleigh

TU6 Terrestrial Channel Performance

Ideal Channel Estimation

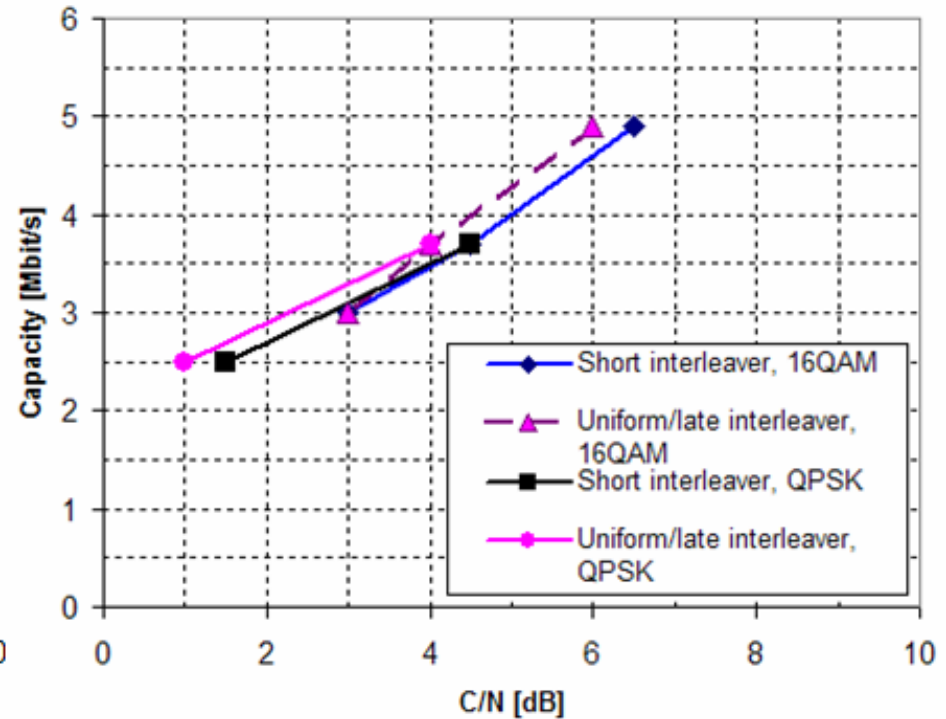
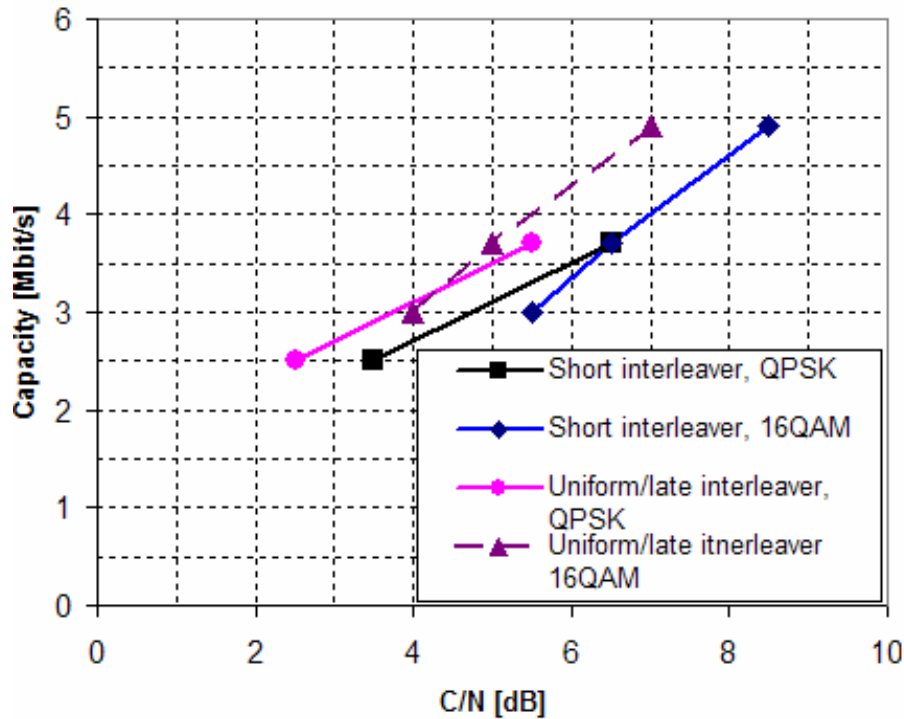

Capacity vs. C/N results for OFDM, TU6 channels, 3km/h (left) and 50km/h (right)

About 1-1.5 dB long time interleaver gain at 3 Kmph

SH-A Reference Demodulator

- Adaptive LMS pilot aided bi-dimensional channel estimator
- Decision-directed for frequency domain channel response

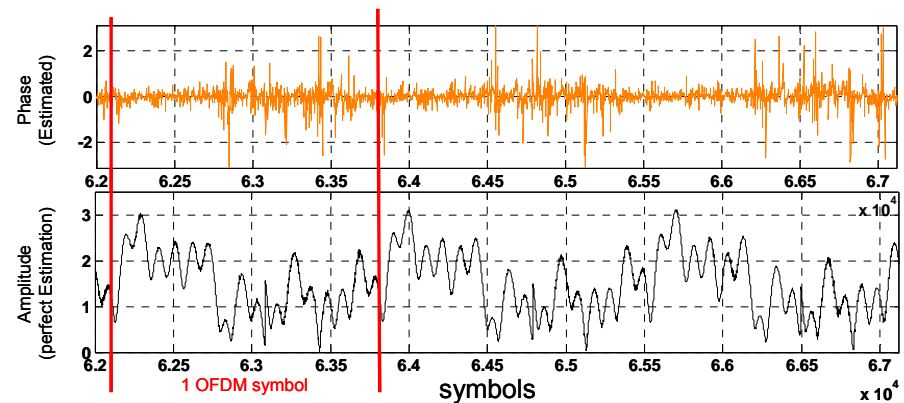
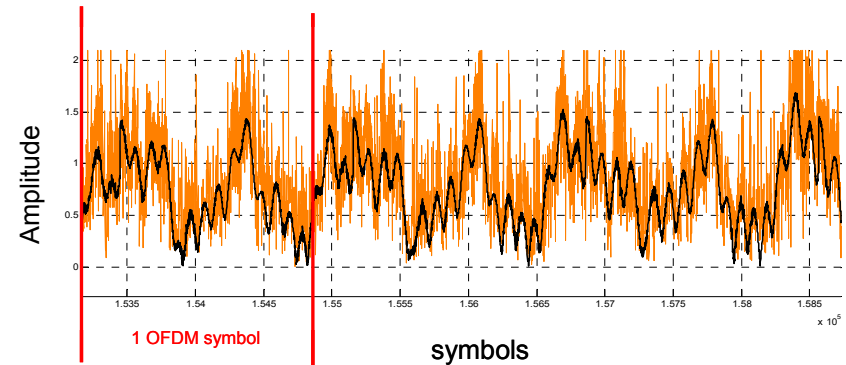

TU6 OFDM performance versus Doppler spread Real Channel Estimation

- Reference SH IG OFDM demodulator simulations (not optimised)
- Short interleaver (200 ms), 2K mode, 5 MHz
- Quite sharp transition for $r=1/2$ FEC
- Smoother transition for $r=1/3$

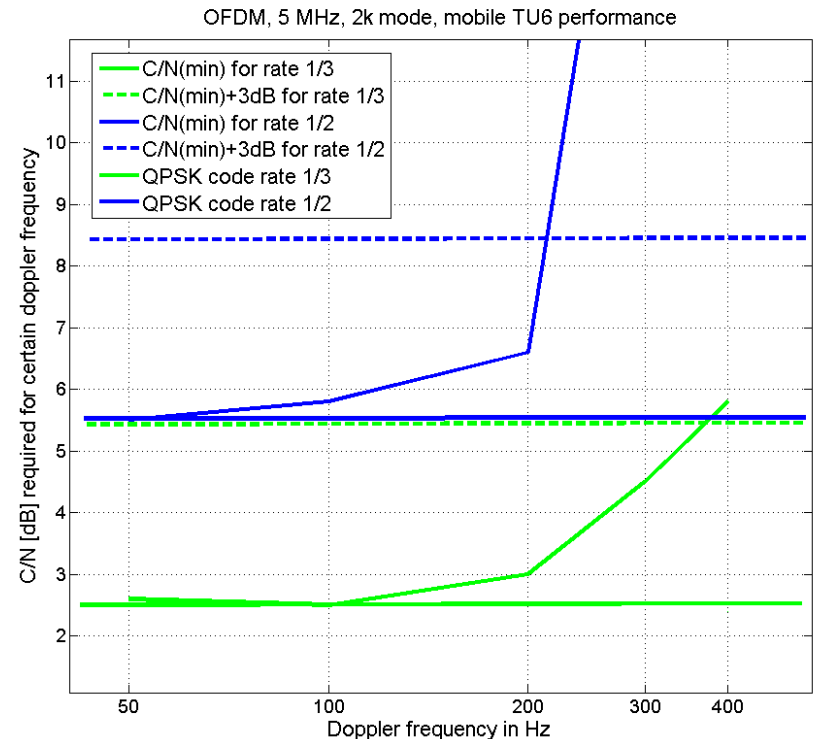

Land Mobile Satellite (LMS) Channel Model

- Fontan et al. LMS statistical model [2001] based on a very comprehensive European measurement database
- Three-state first order Markov model to represent the channel states:
 - Line of sight (LOS) channel (Ricean amplitude distribution)
 - Moderate shadowed channel (Loo's amplitude distribution)
 - Deep shadowed channel (Loo's amplitude distribution)
- Channel elements:
 - direct signal
 - diffuse multipath due to the direct signal illuminating nearby scatterers
 - specularly reflected rays (in case they exist)
 - diffuse multipath associated to the specular rays (in case they exist)

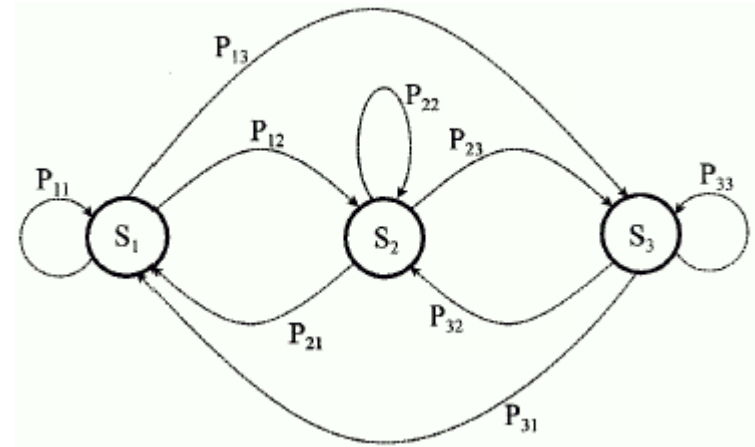

Flat fading assumed (narrowband behaviour) for the bandwidth of interest

Land Mobile Satellite Channel

- Three basic rates of changes related to the channel components:
 - Very slow [gross shadowing/blockage conditions - Markov states]
 - Slow [small-scale shadowing variations - Lognormal distribution]
 - Fast [scattered or specular multipath – Rayleigh distribution]
- Loo's distribution:
 - LOS is lognormally distributed
 - Multipath is Rayleigh distributed

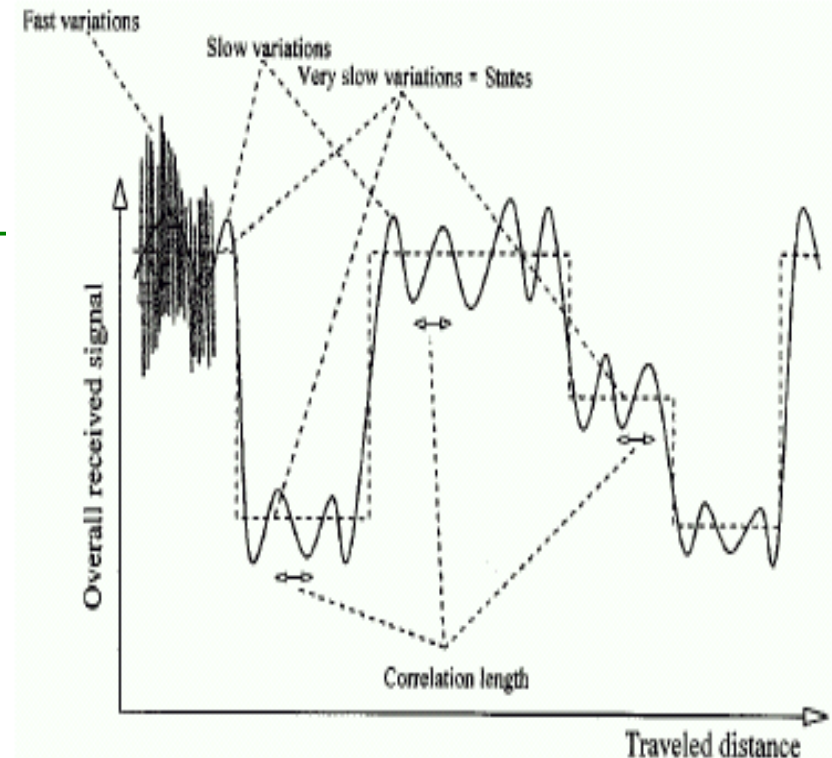

Land Mobile Satellite Channel

Measured narrow-band time-series in a tree-shadowed area at S-Band and 40 degrees elevation.

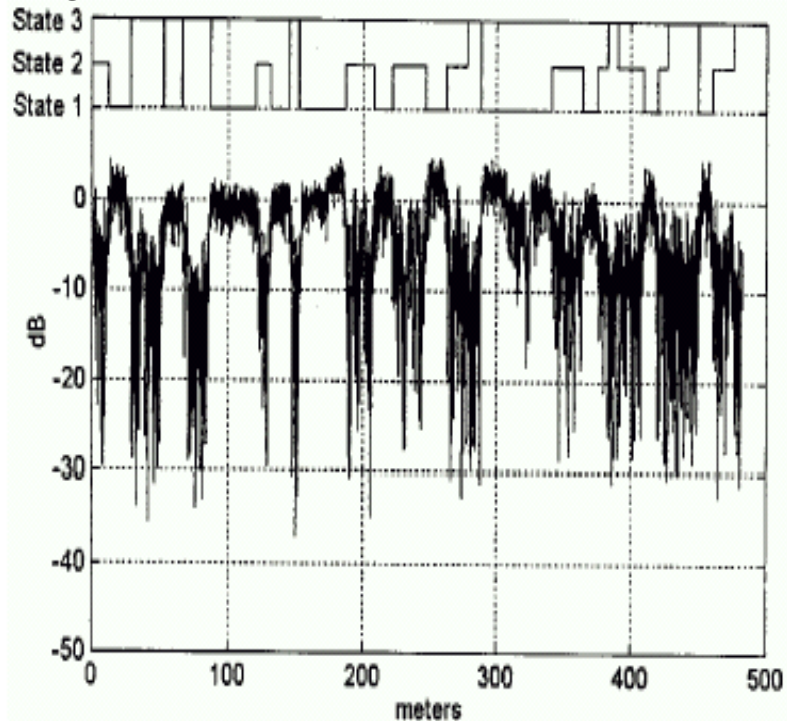

Simulated narrow-band time-series in a tree-shadowed area at S-Band and 40 degrees elevation.

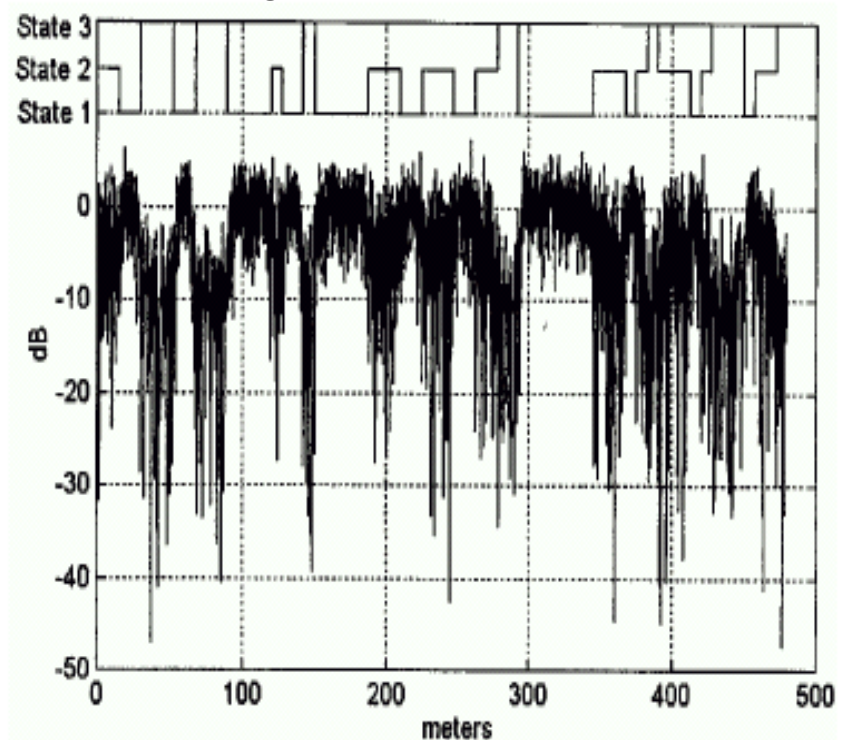

Overall SH-IG Simulation Findings: Class 1 vs Class 2

- For vehicular terminals and IG selected configurations:
 - In LMS-SU, ESR5 fulfillment is above 99% for Class 2, whereas for Class 1 it is from 88 to 98%.
 - In LMS-ITS, ESR5 fulfillment is from 86 to 100% for Class 2, whereas Class 1 cannot achieve 90%.
 - Class 2 often exceeds the targeted performance, even for the lowest satellite EIRP considered, both in LMS-ITS and LMS-SU
 - Class 1 with MPE-IFEC, most likely require interleavers longer than 10 s (see section 10 of the guidelines)
- For handheld reception and IG selected configurations:
 - in LMS-SU and at the highest satellite EIRP considered, the simulation results indicate that ESR5 fulfillment is below target for all physical configurations
 - Class 2 is able to reach an ESR5(20) fulfillment of 88% while Class 1+ MPE-IFEC reaches only 62%



Overall SH-IG Simulation Findings: Different Interleaver Profiles

- The Uniform Late interleaver profile is specifically designed to allow fast zapping in good reception condition
- Also, it allows coexistence of Class 1 and Class 2 in the same network
- These advantages entail some performance penalty:
 - Up to 4 dB in the LMS-SU, for Category 1 terminal at 50 km/h
 - Less than 2 dB in the LMS-ITS, for Category 1 terminal at 50 km/h
 - About 1,5 dB in LMS-SU, for Category 2b terminal at 3 km/h

SH-B Reference Demodulator

- Carrier frequency and symbol clock extraction have not been included in the model as their impacts are considered negligible
- Pilot-aided ML carrier phase estimation with interpolation between pilot sub-slots

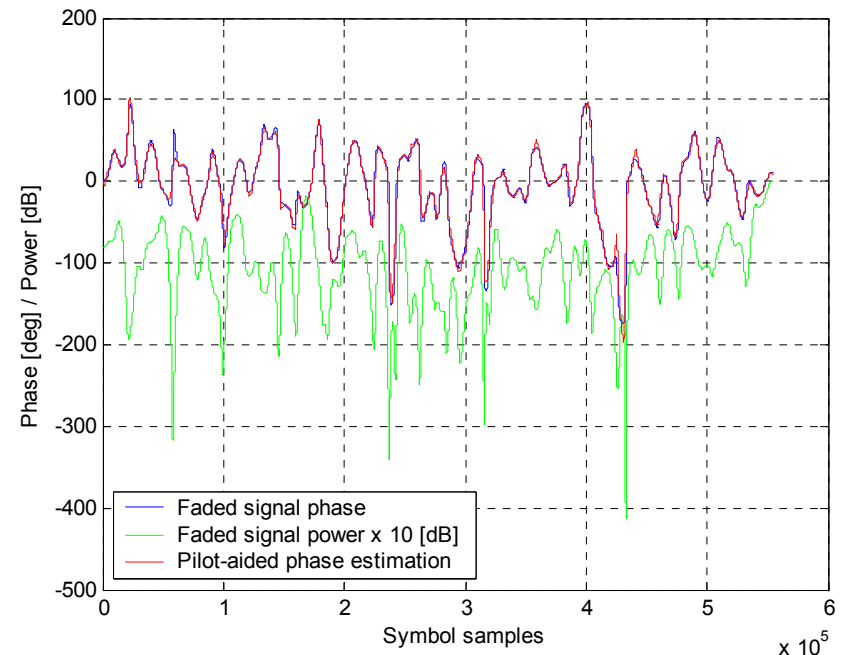



LMS Key Results SH-B with Real Channel Estimation

- QPSK $r=1/3$ over AWGN and Rice ($K=5$ dB, $v=50$ kmph) channel with ideal and real channel estimation
- 200 ms interleaver and infinite length interleaver
- Channel estimation loss is less than 0.15 dB @ $BER=1E-6$
- Limited interleaver size loss of 0.25 @ 50 Kmph

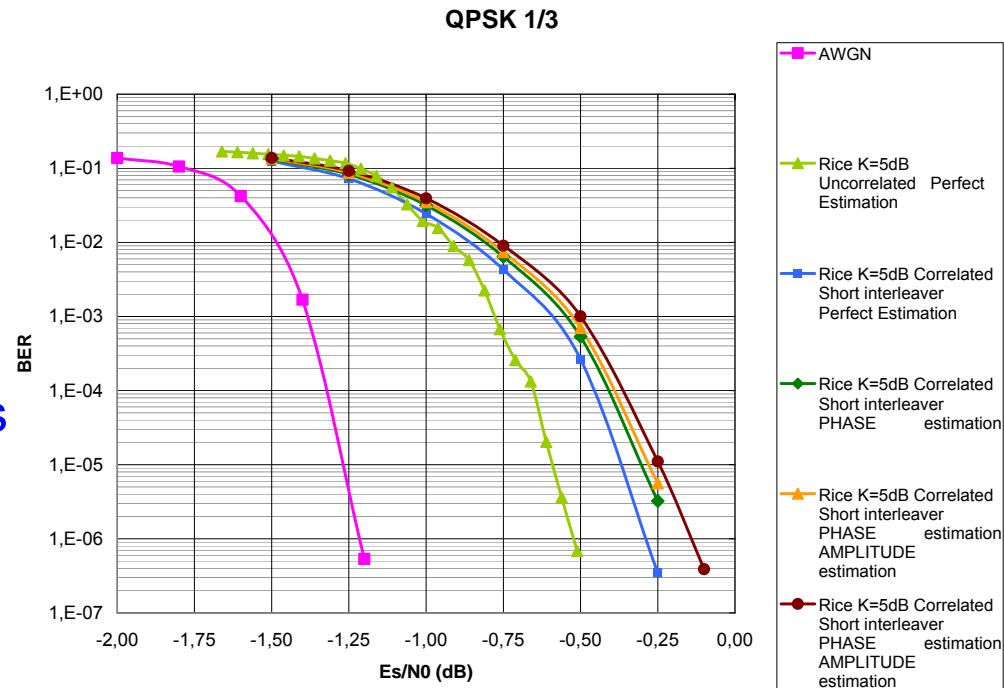



LMS Key Results SH-B with Real Channel Estimation

Reference case	FEC/Interleaver	ESR5 satisfaction % ideal channel estimation	ESR5 satisfaction % reference demodulator channel estimation
Sub-urban (SU) V=3 kmph	Short PL interleaver	45.6	48.9
	Non uniform long PL interleaver	88.5	87.6
	Uniform long PL interleaver	89.3	88.5
	Short PL interleaver plus upper layer FEC	87.6	Not available
Intermediate Tree Shadowing (ITS) V=50 kmph	Short PL interleaver	0.0	0.0
	Non uniform long PL interleaver	25.2	25.6
	Uniform long PL interleaver	80.4	78.2
	Short PL interleaver plus upper layer FEC	19.5	Not available

Summary of ESR5 results at C/N = 10dB with TDM state machine on and ideal or reference demodulator channel



LMS Key Results SH-A with Real Channel Estimation

- QPSK $r=1/3$ over AWGN and Rice ($K=5$ dB, $v=50-100$ kmph) channel with ideal and real channel estimation
- Same demodulator channel estimation as for terrestrial channel (no LMS optimisation)
- 200 ms interleaver and infinite length interleaver
- Channel estimation loss is less than 0.7 dB @ $BER=1E-6$

